



FUNCTIONAL SKILLS MATHS & ENGLISH

LEVEL 1 & 2 EXAMS

WHO WE ARE

Leading training company for 26 years

Intech Centre is an established training provider based in Islington, London, with over 26 years of experience in delivering education, employability and digital skills programmes.

Intech Centre specialises in **Functional Skills English and Maths Level 1 & 2**, helping learners successfully pass Level 1 and Level 2 Functional Skills exams required for university entry, apprenticeships, teacher training, nursing courses and many other professional pathways.

Thousands of learners have used our resources, courses and exam services to achieve nationally recognised qualifications.

[BOOK NOW](#)[LEARN MORE](#)

** The materials in this document are the intellectual property of the relevant awarding organisation and are shared for educational and revision purposes only. Intech Centre does not claim ownership of these materials and all rights remain with the respective awarding body.*

SERVICES

Courses

- Functional Skills Maths
- Functional Skills English

Tutoring

- Functional Skills Maths & English Exam Tutoring

EXAMS

- ➔ Functional Skills **Maths** Level 1 or 2 Exam **in London**
- ➔ Functional Skills **English** Level 1 or 2 Exam **in London**
- ➔ **Online** Functional Skills **Maths** Level 1 or 2 Exam
- ➔ **Online** Functional Skills **English** Level 1 or 2 Exam



www.intechcentre.com



362 Essex Road
Islington N1 3PD



020 7354 5655

BOOK YOUR FUNCTIONAL SKILLS EXAM NOW!

Please check the examination details below before entering your candidate information

Candidate surname

Other names

**Pearson Edexcel
Functional Skills**

Centre Number

Candidate Number

Set 9

Time: 25 minutes

Paper Reference **PMAT2/N09**

Mathematics

Level 2

Section A (Non-Calculator)



You must have:

Pen, HB pencil, eraser, ruler graduated in cm and mm, protractor, pair of compasses. Tracing paper may be used.

Total Marks

My signature confirms that I will not discuss the content of the test with anyone.

Signature: _____

Instructions

- Use **black** ink or ball-point pen.
- **Fill in the boxes** at the top of this page with your name, centre number and candidate number.
- Sign the declaration.
- Answer **all** questions.
- Write your final answers in the boxes provided.
- Answer the questions in the spaces provided – *there may be more space than you need.*
- You **must** show clearly how you get your answers in the spaces provided. Marks will be awarded for your working out.
- Check your working and answers at each stage.
- Diagrams are **not** accurately drawn, unless otherwise indicated.
- **Calculators may not be used.**
- Take the value of π to be 3.14

Information

- The total mark for this section is 16.
- The marks for **each** question are shown in brackets
– *use this as a guide as to how much time to spend on each question.*
- This sign shows where marks will be awarded for showing your checks.

Advice

- Read each question carefully before you start to answer it.
- Check your answers if you have time at the end.

Turn over ►

P69192A

©2021 Pearson Education Ltd.

1/1/1



Pearson

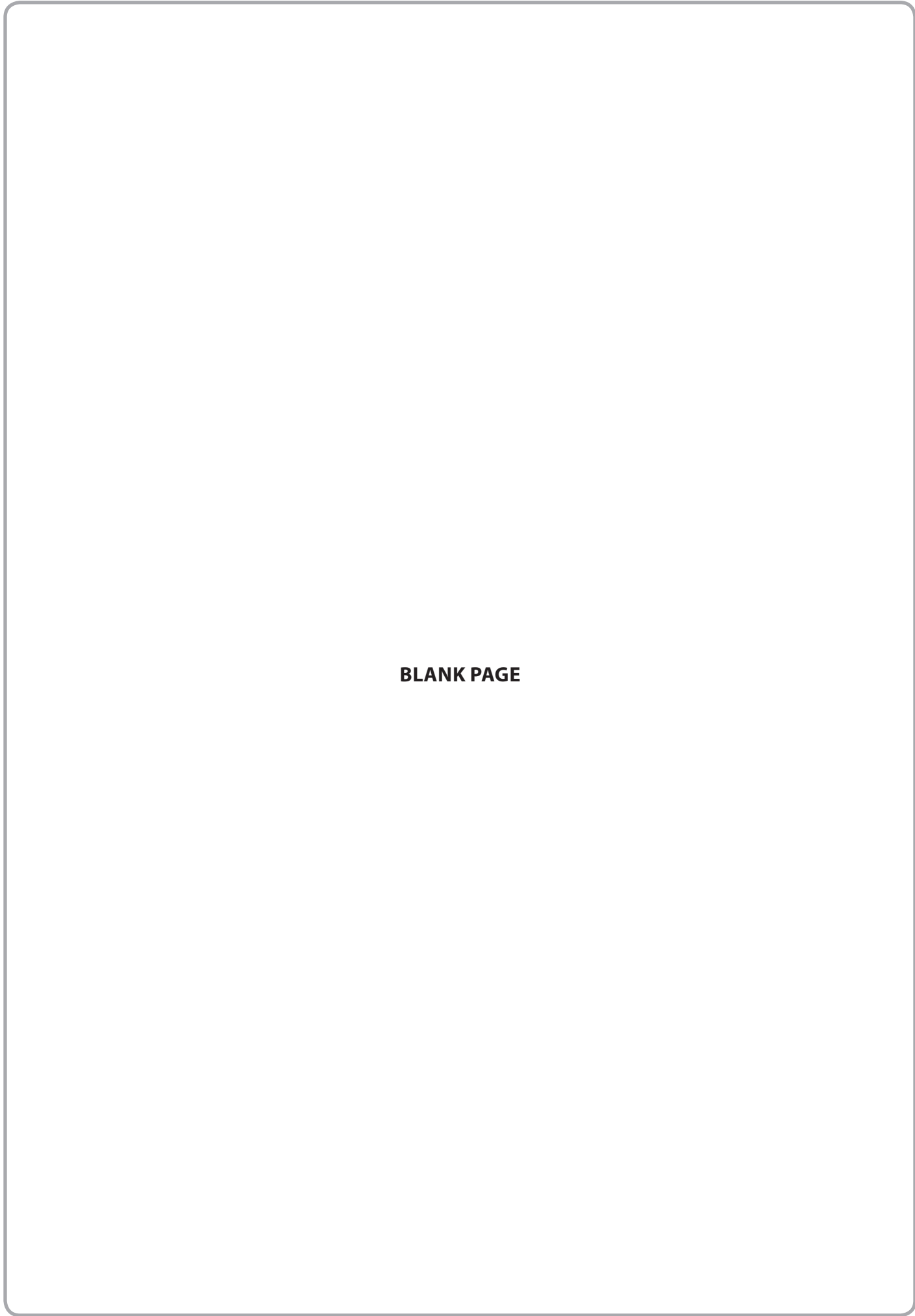

BLANK PAGE

DO NOT WRITE IN THIS AREA

DO NOT WRITE IN THIS AREA

DO NOT WRITE IN THIS AREA

DO NOT WRITE IN THIS AREA

DO NOT WRITE IN THIS AREA

DO NOT WRITE IN THIS AREA



SECTION A

Answer ALL questions. Write your answers in the spaces provided.

- 1 Shannan has a new car.

The petrol tank has a maximum capacity of 48 litres.

The cost of petrol is 126.7p per litre.

Shannan thinks it will cost less than £70 to completely fill an empty tank with petrol.

Use **estimation** to check if Shannan is correct.

You **must** show your working.

(3)

(Total for Question 1 is 3 marks)



2 Henry is designing the car park for a new shopping centre.
The total number of parking spaces at the shopping centre will be 900

150 of the parking spaces will be for staff.
The rest of the parking spaces will be for visitors.

Henry wants 6% of the visitor parking spaces to be parking spaces for disabled visitors.

Work out the number of parking spaces for disabled visitors in this car park.

(3)

(Total for Question 2 is 3 marks)

DO NOT WRITE IN THIS AREA

DO NOT WRITE IN THIS AREA

DO NOT WRITE IN THIS AREA

DO NOT WRITE IN THIS AREA

DO NOT WRITE IN THIS AREA

DO NOT WRITE IN THIS AREA



3 Here is a list of numbers.

12.96 12.096 12.9 12.45 12.1 12.738 12.62

(a) Find the median.

(2)

(b) Work out $\frac{7}{8} - \frac{3}{5}$

You **must** show your working.

(2)

(Total for Question 3 is 4 marks)



4 Raffi wants a two-storey extension built on the side of his house.

This scale diagram shows the plan view of the floor for each storey.



Scale 1 : 50

Raffi looks at the websites for different builders.

The table shows the cost per m² to build a one-storey extension.

Builder	A	B	C	D	E	F	G	H
Cost per m ² (£)	1300	1350	1300	1325	1300	1340	1350	1290

Raffi will use the mode of these costs to help work out the expected cost to build this two-storey extension.

He also knows that the cost per m² to build a two-storey extension is $1\frac{1}{2}$ times the cost per m² to build a one-storey extension.

DO NOT WRITE IN THIS AREA

DO NOT WRITE IN THIS AREA

DO NOT WRITE IN THIS AREA

DO NOT WRITE IN THIS AREA

DO NOT WRITE IN THIS AREA

DO NOT WRITE IN THIS AREA



Work out the expected cost to build the two-storey extension for Raffi.
You **must** show your working.

(6)

£

(Total for Question 4 is 6 marks)

TOTAL FOR SECTION A IS 16 MARKS



P 6 9 1 9 2 A 0 7 0 8

DO NOT WRITE IN THIS AREA

DO NOT WRITE IN THIS AREA

DO NOT WRITE IN THIS AREA

BLANK PAGE



Please check the examination details below before entering your candidate information

Candidate surname

Other names

**Pearson Edexcel
Functional Skills**

Centre Number

Candidate Number

Set 9

Time: 1 hour 30 minutes

Paper Reference **PMAT2/C09**

Mathematics

Level 2

Section B (Calculator)



You must have:

Pen, calculator, HB pencil, eraser, ruler graduated in cm and mm, protractor, pair of compasses. Tracing paper may be used.

Total Marks

My signature confirms that I will not discuss the content of the test with anyone.

Signature: _____

Instructions

- Use **black** ink or ball-point pen.
- **Fill in the boxes** at the top of this page with your name, centre number and candidate number.
- Sign the declaration.
- Answer **all** questions.
- Write your final answers in the boxes provided.
- Answer the questions in the spaces provided – *there may be more space than you need.*
- You **must** show clearly how you get your answers in the spaces provided. Marks will be awarded for your working out.
- Check your working and answers at each stage.
- Diagrams are **not** accurately drawn, unless otherwise indicated.
- **Calculators may be used.**
- If your calculator does not have a π button take the value of π to be 3.14

Information

- The total mark for this section is 48.
- The total mark for this paper is 64.
- The marks for **each** question are shown in brackets
– *use this as a guide as to how much time to spend on each question.*
- This sign shows where marks will be awarded for showing your checks.

Advice

- Read each question carefully before you start to answer it.
- Check your answers if you have time at the end.

Turn over ►

P68474A

©2021 Pearson Education Ltd.

1/1/1/1



P 6 8 4 7 4 A 0 1 2 0



Pearson

SECTION B

Answer ALL questions. Write your answers in the spaces provided.

1 Thalia owns a chocolate factory.

The workers in the factory work 7 hours per day.
They produce 65 boxes of chocolate per hour.

Thalia gets an order for 9100 boxes of chocolates.

Work out the number of days needed to produce 9100 boxes of chocolates.

(3)

(Total for Question 1 is 3 marks)

DO NOT WRITE IN THIS AREA

DO NOT WRITE IN THIS AREA

DO NOT WRITE IN THIS AREA

DO NOT WRITE IN THIS AREA

DO NOT WRITE IN THIS AREA

DO NOT WRITE IN THIS AREA



- 2 Thalia has 6 machines to produce chocolate in her factory.
Each machine produces the same amount of chocolate.

It takes $3\frac{1}{2}$ hours for these 6 machines to produce enough chocolate to fill a crate with chocolate bars.

On Tuesday only 4 of the machines are working.

Work out the number of hours the 4 machines will take to produce the chocolate needed to fill a crate with chocolate bars.

(3)

(Total for Question 2 is 3 marks)



- 3 The scatter diagram shows information about the outside temperature and the number of gas units used to heat a house on each of ten days during January.

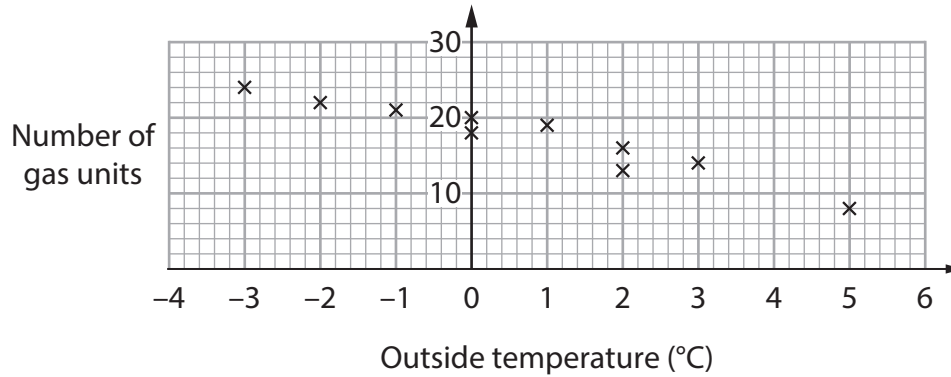

The range of the number of gas units used to heat this house each day during October was 11 gas units per day.

Jenson thinks the number of gas units used to heat this house each day is more consistent in October than in the ten days in January.

- (a) Is Jenson correct?
Show why you think this.

(3)

Jenson also thinks there is no relationship between the outside temperature and the number of gas units used to heat this house in these ten days in January.

- (b) Is Jenson correct?
Give a reason for your answer.

(1)

(Total for Question 3 is 4 marks)



- 4 Kady runs a household waste centre.
Rubbish collected at the centre is either sent for recycling or sent to landfill.

The table shows information about the weight of each type of rubbish sent for recycling last month.

Rubbish type	Weight (tonnes)
Garden waste	224.56
Wood and cardboard	101.81
Metal	37
Glass, soil and rubble	138.9
Electrical	16.54
Other	82.45

The total weight of rubbish collected at the centre last month was 653.64 tonnes.

What percentage of all the rubbish collected last month was sent for recycling?
Give your answer correct to the nearest whole number.

(3)

%

(Total for Question 4 is 3 marks)



- 5 Natalie will plant flower bulbs on a road roundabout.
The roundabout is in the shape of a circle with diameter 14 m.

Natalie will plant the flower bulbs in a circle 75 cm from the edge of the roundabout.
The dashed line in the sketch below shows where the flower bulbs will be planted.

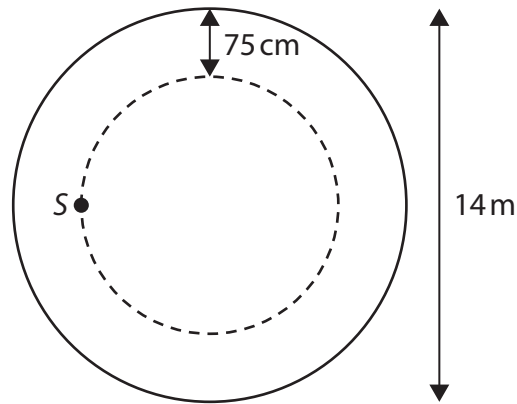

Natalie will plant a flower bulb every 25 cm starting from point S.

The flower bulbs are sold in packs.
Each pack has 16 flower bulbs.

How many packs of flower bulbs will Natalie need?

(5)

DO NOT WRITE IN THIS AREA

DO NOT WRITE IN THIS AREA

DO NOT WRITE IN THIS AREA

DO NOT WRITE IN THIS AREA

DO NOT WRITE IN THIS AREA

DO NOT WRITE IN THIS AREA



DO NOT WRITE IN THIS AREA

DO NOT WRITE IN THIS AREA

DO NOT WRITE IN THIS AREA

DO NOT WRITE IN THIS AREA

DO NOT WRITE IN THIS AREA

DO NOT WRITE IN THIS AREA



(Total for Question 5 is 5 marks)



- 6 Andrew is training to run in the New York Marathon.
The New York Marathon is 26.2 miles long.

The qualifying times to run in the New York Marathon are shown in the table below.

Age (years)	Time (hours : mins)
18 – 34	2 : 53
35 – 39	2 : 55
40 – 44	2 : 58
45 – 49	3 : 05
50 – 54	3 : 14
55 – 59	3 : 23
60 – 64	3 : 34
65 – 69	3 : 45
70 – 74	4 : 10
75 – 79	4 : 30
80 +	4 : 55

Andrew is 51 years old.
His current average running speed is 8 miles per hour.

Andrew thinks he will need to run at a faster speed to be able to qualify for the New York Marathon.

Is Andrew correct?
Show why you think this.

(3)

(Total for Question 6 is 3 marks)



7 Here is a sketch of a square based pyramid and one of the triangular faces.

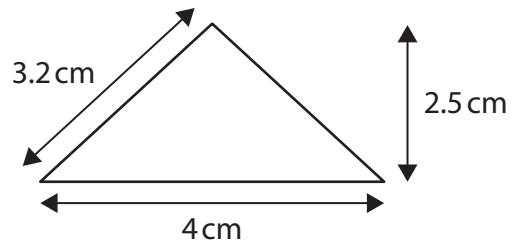
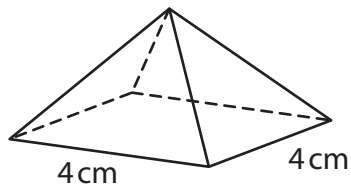

(a) Draw an accurate net of this pyramid on the centimetre grid below.

(3)

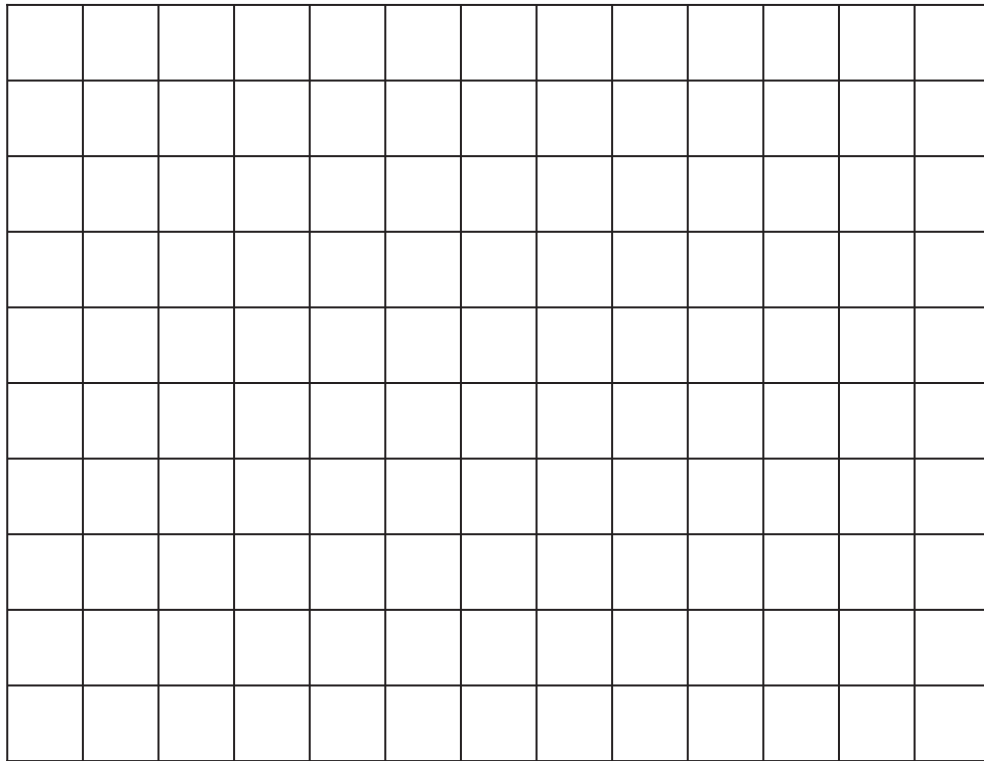

The base of a tin of paint is placed on the floor.
The tin of paint is in the shape of a cylinder.

(b) Draw a sketch of the plan view of the tin of paint.

(1)

(Total for Question 7 is 4 marks)



- 8 Dave needs to make 3500 lbs of concrete mix using cement, sand and gravel. He will mix cement, sand and gravel in the ratio 1 : 2 : 5 by weight.

Cement, sand and gravel are sold in kilograms.

Dave uses this graph to convert between lb and kg.

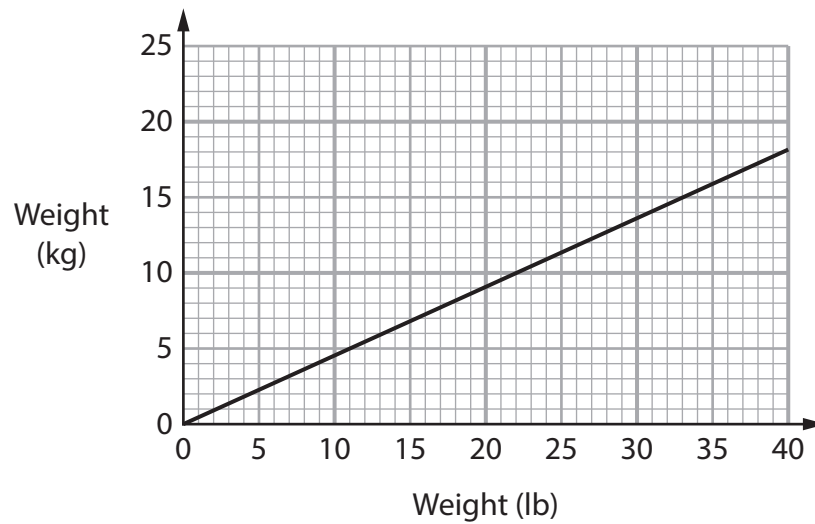

- (a) Work out the weight, in kilograms, of cement, of sand and of gravel that Dave needs to buy.
You **must** show your working.

(5)

DO NOT WRITE IN THIS AREA

DO NOT WRITE IN THIS AREA

DO NOT WRITE IN THIS AREA

DO NOT WRITE IN THIS AREA

DO NOT WRITE IN THIS AREA

DO NOT WRITE IN THIS AREA



DO NOT WRITE IN THIS AREA

DO NOT WRITE IN THIS AREA

DO NOT WRITE IN THIS AREA

DO NOT WRITE IN THIS AREA

DO NOT WRITE IN THIS AREA

DO NOT WRITE IN THIS AREA

[Empty space for student response]

Cement	kg
Sand	kg
Gravel	kg



(b) Show a check of your ratio calculation.

(1)

[Empty space for student response]

(Total for Question 8 is 6 marks)



9 Here is a centimetre grid.

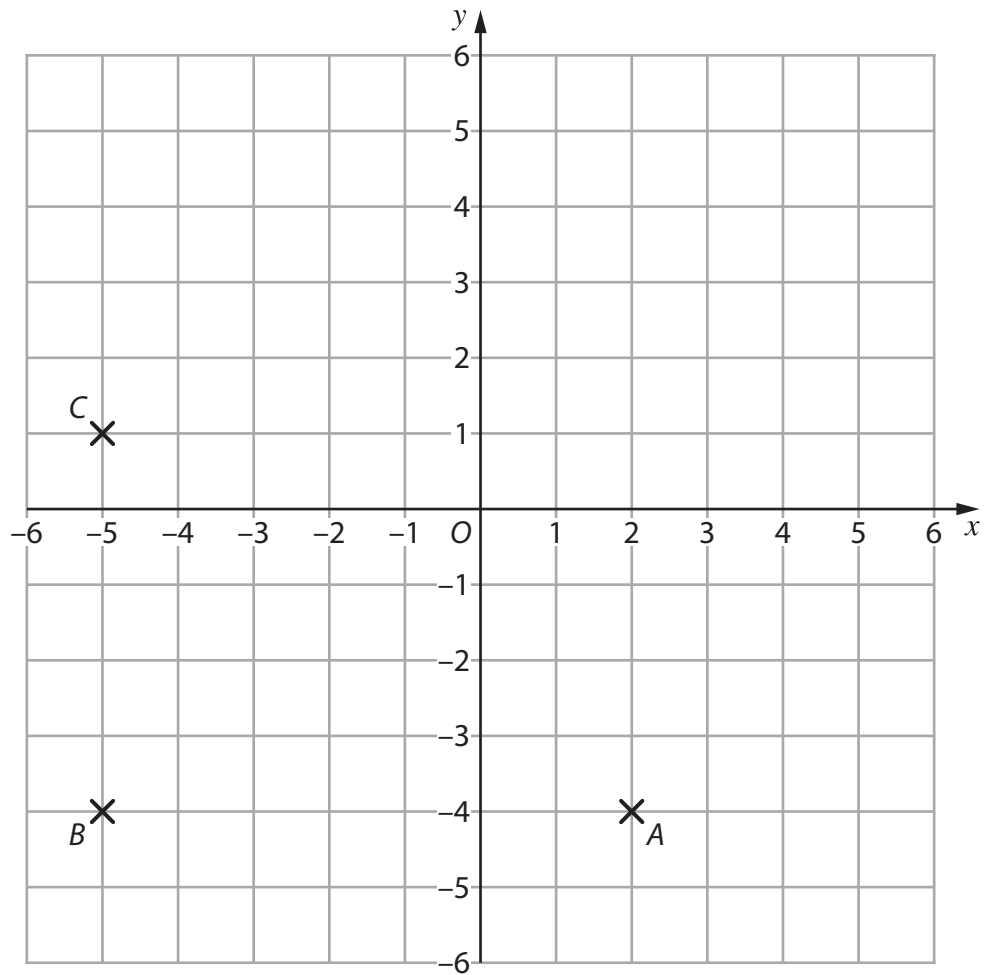

(a) Write down the coordinates of point *B*.

(1)

D is a point on the grid.

The trapezium *ABCD* has

- exactly 2 right angles
- one side of length 9 cm.

(b) Plot a possible position for point *D* on the grid.

(2)

(Total for Question 9 is 3 marks)



10 Here is a cone.

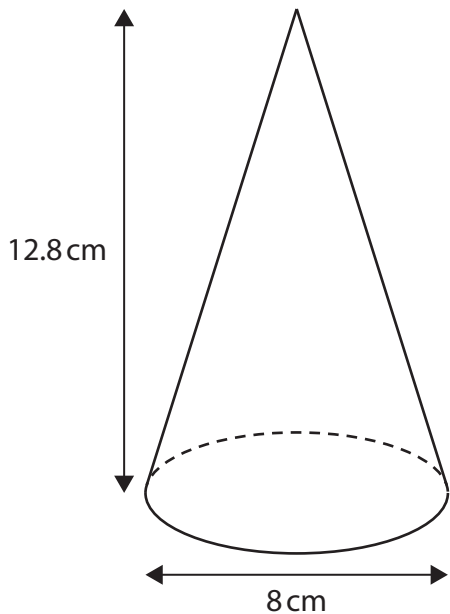

$$V = \frac{1}{3} \pi r^2 h$$

V is the volume
 r is the radius of the base of the cone
 h is the vertical height

Work out the volume of this cone.
Remember to state the units.

(3)

(Total for Question 10 is 3 marks)



11 Darius restores old furniture.
He has 12 chairs and 3 tables to restore.

Darius writes a list of the costs to restore all of the chairs and all the tables.

Costs	
tables and chairs	free
7 tins of wood oil	£12.50 each
10.5 metres fabric	£6.90 per metre
foam cushions	£82.50

Darius sells each table for £127 and each chair for £32

Work out the percentage profit Darius makes after selling all the chairs and all the tables.

Give your answer correct to 1 decimal place.

(5)

DO NOT WRITE IN THIS AREA

DO NOT WRITE IN THIS AREA

DO NOT WRITE IN THIS AREA

DO NOT WRITE IN THIS AREA

DO NOT WRITE IN THIS AREA

DO NOT WRITE IN THIS AREA



DO NOT WRITE IN THIS AREA

DO NOT WRITE IN THIS AREA

DO NOT WRITE IN THIS AREA

DO NOT WRITE IN THIS AREA

DO NOT WRITE IN THIS AREA

DO NOT WRITE IN THIS AREA

[Large empty rectangular area for writing]

%

(Total for Question 11 is 5 marks)



12 Jasmine is doing a survey about learning to drive.

The table shows information about the number of driving lessons 60 people had before passing their driving test.

Number of driving lessons	Frequency		
1 to 15	6		
16 to 30	18		
31 to 45	25		
46 to 60	11		

Jasmine estimates that the mean number of driving lessons these people had before passing their driving test is more than 35 lessons.

- (a) Is this estimate of the mean correct?
Show why you think this.

(3)

DO NOT WRITE IN THIS AREA

DO NOT WRITE IN THIS AREA

DO NOT WRITE IN THIS AREA

DO NOT WRITE IN THIS AREA

DO NOT WRITE IN THIS AREA

DO NOT WRITE IN THIS AREA





(b) Use a reverse calculation to show a check of your answer.

(1)

One of these 60 people is chosen at random.

(c) What is the probability that this person had more than 30 lessons before passing their driving test?
Give your answer as a decimal.

(2)

(Total for Question 12 is 6 marks)

TOTAL FOR SECTION B IS 48 MARKS
TOTAL FOR PAPER IS 64 MARKS



P 6 8 4 7 4 A 0 1 7 2 0

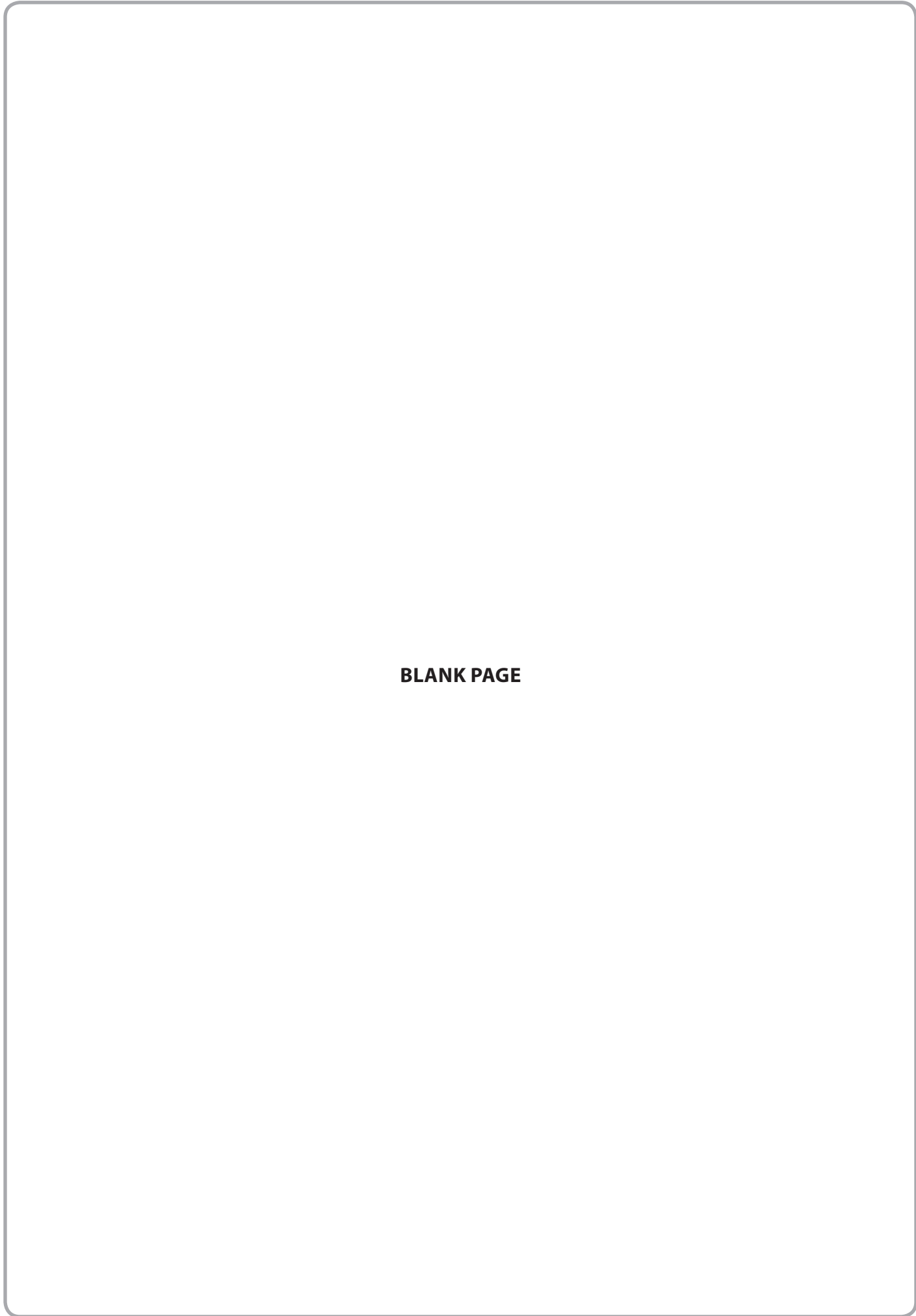

BLANK PAGE

DO NOT WRITE IN THIS AREA

DO NOT WRITE IN THIS AREA

DO NOT WRITE IN THIS AREA

DO NOT WRITE IN THIS AREA

DO NOT WRITE IN THIS AREA

DO NOT WRITE IN THIS AREA



DO NOT WRITE IN THIS AREA

DO NOT WRITE IN THIS AREA

DO NOT WRITE IN THIS AREA

DO NOT WRITE IN THIS AREA

DO NOT WRITE IN THIS AREA

DO NOT WRITE IN THIS AREA

BLANK PAGE



P 6 8 4 7 4 A 0 1 9 2 0

DO NOT WRITE IN THIS AREA

DO NOT WRITE IN THIS AREA

DO NOT WRITE IN THIS AREA

BLANK PAGE





Book Your Functional Skills Exam Now!

Intech Centre is a leading training, careers and examination centre based in Islington, London, delivering Functional Skills Maths and English courses and exams for over 26 years.

[→ Book Now!](#)

→ Book Your Exams & Courses

Qualification	Private Course	Online Exam	Exam in London
Functional Skills Maths Level 1 & 2	Enrol on Course	Book Online Exam	Book London Exam
Functional Skills English Level 1 & 2	Enrol on Course	Book Online Exam	Book London Exam

Why Intech Centre?

- Over **26 years' experience** as a UK training and exam centre in London.
- **City & Guilds Functional Skills Maths and English exams**, Ofqual regulated and nationally recognised.
- Flexible **online learning** with 24/7 access plus online or centre-based exam options.
- Ideal if you still need GCSE Maths or English equivalent for university entry, teacher training, apprenticeships or employment.

CALL US FOR MORE INFORMATION:

 **020 7354 5655**

 www.intechcentre.com

 info@intechcentre.com