



FUNCTIONAL SKILLS MATHS & ENGLISH

LEVEL 1 & 2 EXAMS

WHO WE ARE

Leading training company for 26 years

Intech Centre is an established training provider based in Islington, London, with over 26 years of experience in delivering education, employability and digital skills programmes.

Intech Centre specialises in **Functional Skills English and Maths Level 1 & 2**, helping learners successfully pass Level 1 and Level 2 Functional Skills exams required for university entry, apprenticeships, teacher training, nursing courses and many other professional pathways.

Thousands of learners have used our resources, courses and exam services to achieve nationally recognised qualifications.

[BOOK NOW](#)

[LEARN MORE](#)

** The materials in this document are the intellectual property of the relevant awarding organisation and are shared for educational and revision purposes only. Intech Centre does not claim ownership of these materials and all rights remain with the respective awarding body.*

SERVICES

Courses

- Functional Skills Maths
- Functional Skills English

Tutoring

- Functional Skills Maths & English Exam Tutoring

EXAMS

- ➔ Functional Skills **Maths** Level 1 or 2 Exam **in London**
- ➔ Functional Skills **English** Level 1 or 2 Exam **in London**
- ➔ **Online** Functional Skills **Maths** Level 1 or 2 Exam
- ➔ **Online** Functional Skills **English** Level 1 or 2 Exam



www.intechcentre.com



362 Essex Road
Islington N1 3PD



020 7354 5655

BOOK YOUR FUNCTIONAL SKILLS EXAM NOW!



NCFE Level 2 Functional Skills Qualification in Mathematics (603/5060/X)

Paper number: P001457
Section B: Calculator Test



Time allowed: 1 hour 30 minutes

Learner instructions

- Answer **all** questions.
- Read each question carefully.
- Write your answers in the spaces provided.
- Show your working, as marks may be awarded for working.
- State units in your answers, where appropriate.
- Check your work.
- Use $\pi = 3.14$

Learner information

- Section B contains **Activities 2, 3 and 4**.
- The maximum mark for this section is **45**.
- The marks available for **each** question are shown in brackets.

Resources

You will need a:

- pen, with black or blue ink
- pencil and eraser
- 30 cm ruler
- protractor
- calculator.

If extra pages are used, please make sure your name and centre name are on them and they are securely fastened to this booklet.

Please complete the details below clearly and in BLOCK CAPITALS.

Learner name _____

Centre name _____

Learner number

Centre number

Do not turn over until the invigilator tells you to do so.

PAST PAPER

This page is intentionally left blank.

Activity 2: Hotel

2 (a) Fiona is on a work placement in a hotel.

The hotel has a loyalty programme for the guests.

There are three million, four hundred thousand and nineteen guests currently signed up to the loyalty programme worldwide.

Write three million, four hundred thousand and nineteen as a number.

[1 mark]

Your answer:

2 (b) There are 216 guests currently staying at the hotel.

81 of these guests are signed up to the loyalty programme.

Fiona thinks that more than $\frac{4}{10}$ of these guests are signed up to the loyalty programme.

Is she correct?

Show how you decide.

[2 marks]

| | |
|--------------|--|
| | |
| Your answer: | |

Please turn over

2 (c)

The table below shows information about the 216 guests staying at the hotel on Sunday.

| Sunday | |
|-----------------------|------------------|
| Number of nights stay | Number of guests |
| 1 | 59 |
| 2 | 42 |
| 3 | 65 |
| 4 | 25 |
| 5 | 16 |
| 6 | 5 |
| 7 | 4 |
| Total | 216 |

Every Sunday and Monday, guests who will be staying for more nights than the mode are given a voucher for £10 off food and drink in the restaurant.

The total value of the vouchers given to guests on Monday was 4% more than the total value of the vouchers given on Sunday.

What was the total value of the vouchers given on Monday?

[4 marks]

PAST PAPER

Your answer:

£

Please turn over

2 (d)

Fiona uses this formula to work out the number of loyalty points earned by each guest last year.

$$L = 300 \left(s + \frac{r}{2} \right)$$

Where L = number of loyalty points collected in a year

s = number of nights stayed in a suite

r = number of nights stayed in a regular room

She then uses this table to put each guest into one of five tiers based on the number of loyalty points they earned.

| Tier | Loyalty points collected in a year |
|------|------------------------------------|
| 1 | 0 – 599 |
| 2 | 600 – 1499 |
| 3 | 1500 – 2999 |
| 4 | 3000 – 4999 |
| 5 | 5000+ |

Last year, Mrs Jones stayed 3 nights in a suite and 7 nights in a regular room.

Which tier should Fiona put Mrs Jones into?

You must show all your working.

[2 marks]

Your answer:

Tier

2 (e) A luxury room in the hotel has a bathtub 60.3 inches long.

What is the length of the bathtub in centimetres?

Use the conversion 1 inch = 2.54 cm

Give your answer correct to 1 decimal place.

[2 marks]

| | |
|-------------------|-----------|
| PAST PAPER | |
| Your answer: | cm |

Please turn over

2 (f)

Fiona helps with organising an event at the hotel.

The diagram below shows the dimensions of the dance floor.

The shape of the dance floor has one line of symmetry.

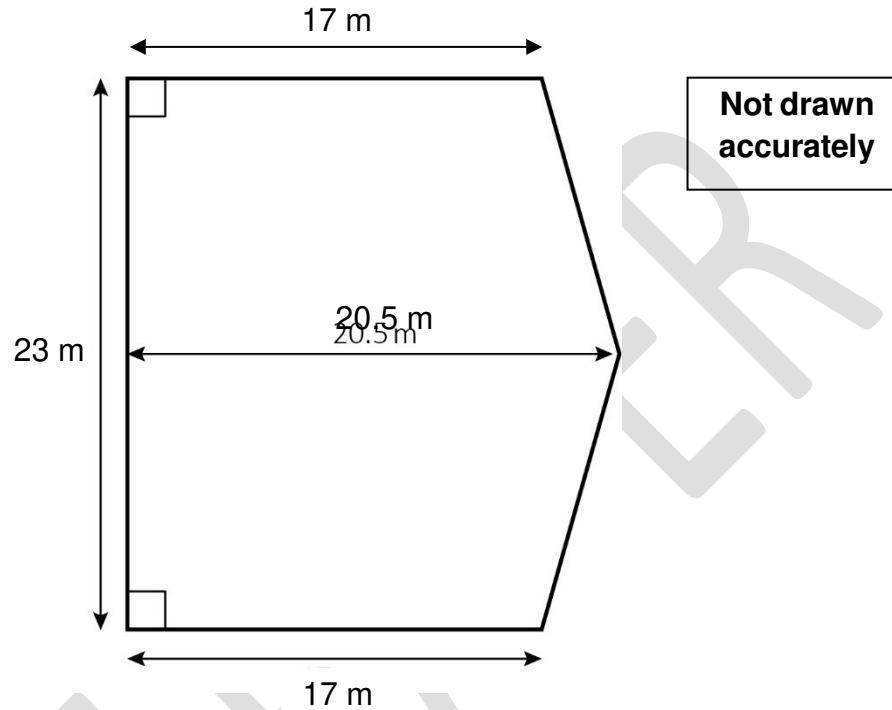

On the dance floor, each person must have at least 0.9 m^2 of floor space.

Work out the maximum number of people who can use this dance floor at one time.

[4 marks]

Your answer:

people

[Total marks: 15]

Activity 3: Product design

3 (a) Calista is a product designer at a toy factory.

The diagram shows a metal part in a toy robot.

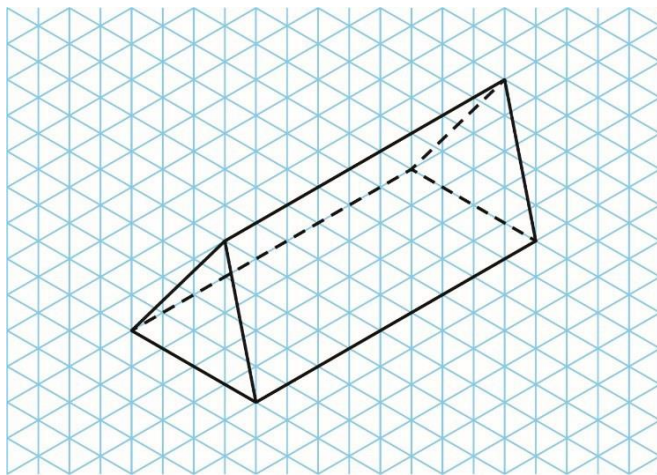

What is the name of this shape?

Tick the correct answer.

A pyramid

B cylinder

C prism

D cuboid

[1 mark]

Please turn over

3 (b) Calista designs a plastic piece for a game.

The piece is in the shape of a cone.
The diagram shows the dimensions of the piece.

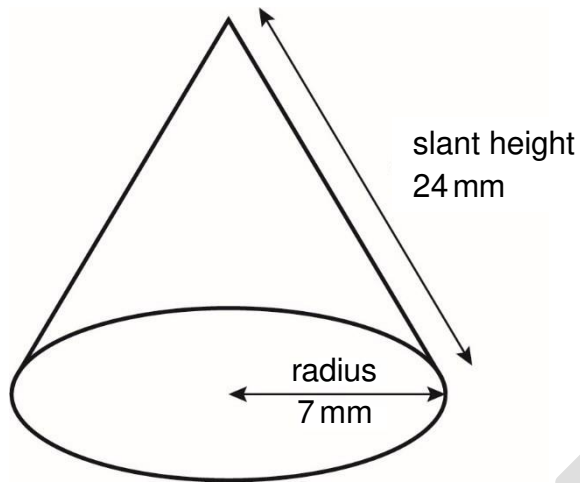

Not drawn
accurately

Work out the surface area of the piece.

Use $A = \pi r^2 + \pi rs$

where A = surface area of a cone

r = radius of the circular base

s = slant height of the cone

Use $\pi = 3.14$

[2 marks]

Blank area for working out the surface area.

Your answer:

mm²

- 3 (c)** Calista mixes three colours to make teal-coloured paint for the plastic game pieces.
She mixes blue, green and yellow paint in the ratio 4 : 2 : 1

Calista wants to make 14 litres of teal-coloured paint.
She thinks she needs 1.6 litres of yellow paint.

Is she correct?

Show how you decide.

[2 marks]

| | |
|--------------|--|
| PAST PAPER | |
| Your answer: | |

Please turn over

3 (d) The graph below shows the information about the settings and fault rate of a machine in the toy factory.

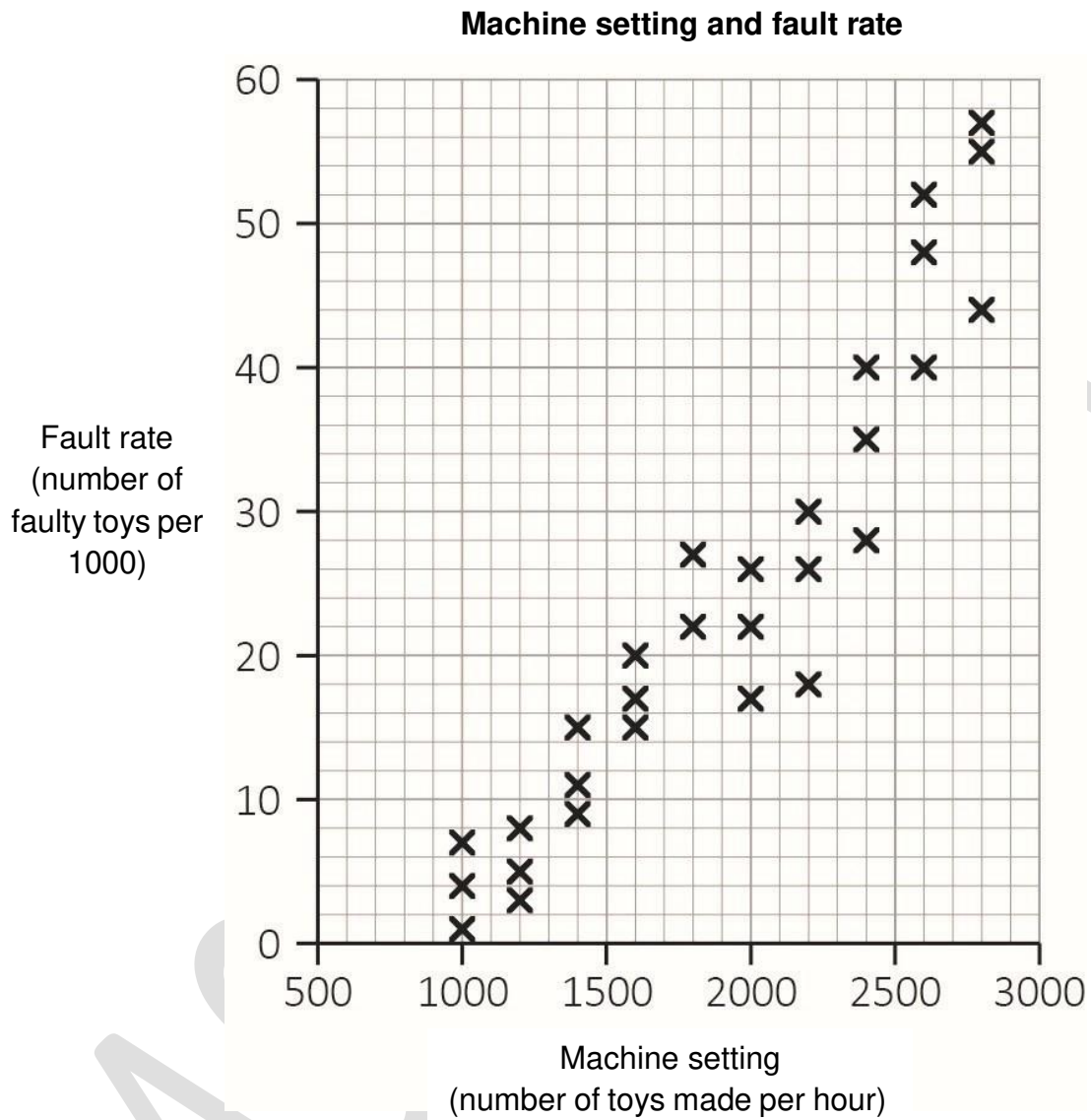

What was the highest fault rate when the machine was set to make 1600 toys per hour?

[1 mark]

Your answer:

faulty toys per 1000

**This page is intentionally left blank.
Please turn over for the next question.**

- 3 (e)** The graph below shows the information about the settings and fault rate of a machine in the toy factory.

Machine setting and fault rate

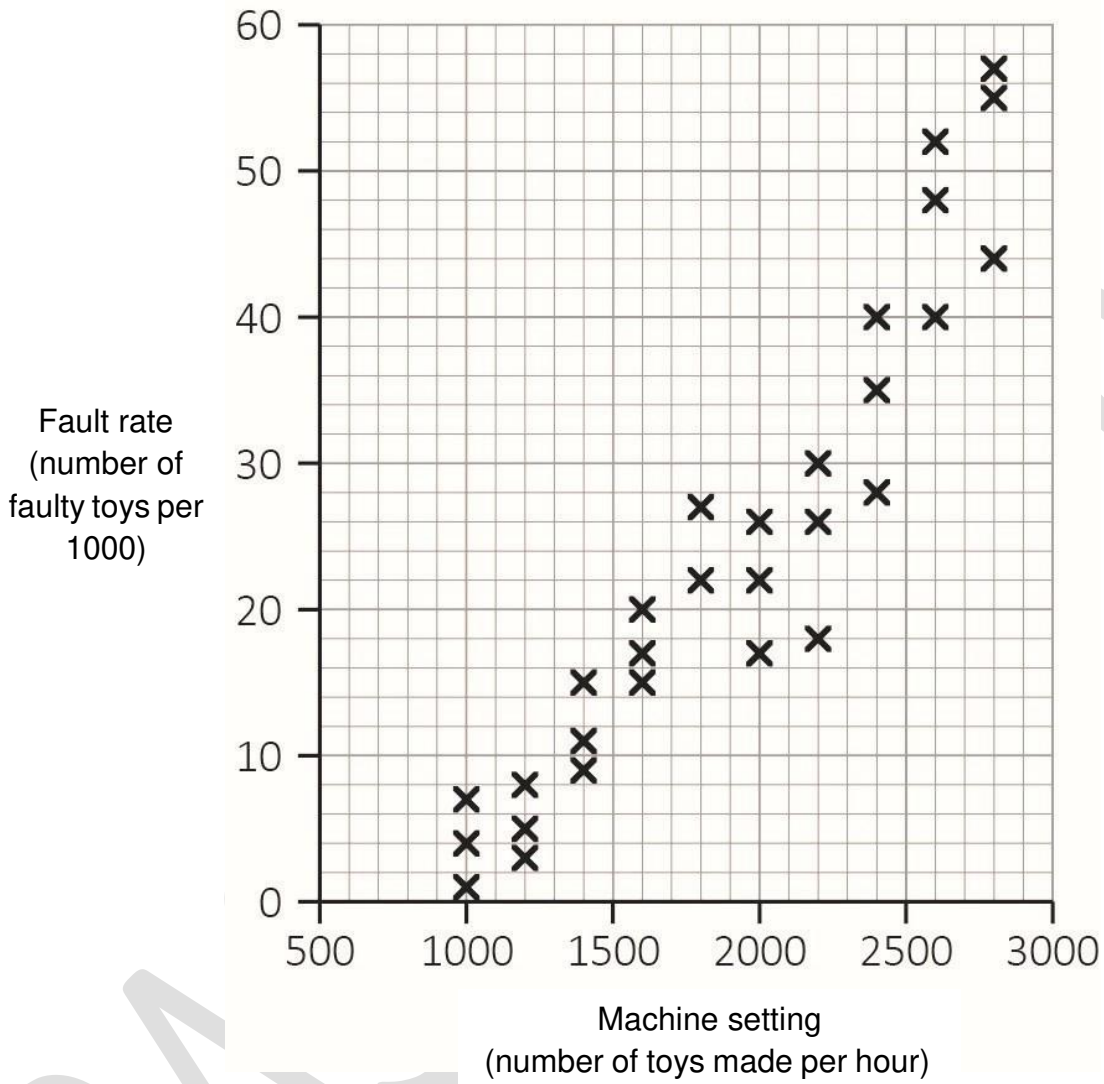

Calista is writing a report.
She uses a line of best fit to find the fault rate when the machine setting is 2500

Calista writes, "The fault rate when the machine setting is 2500 as a percentage of the median fault rate when the machine setting is 2600 is more than 90%."

Is she correct?

Show how you decide.

[5 marks]

PAST PAPER

Your answer:

Please turn over

3 (f)

Calista has this data about the volume of plastic used to make the toys she has designed.

| Volume of plastic (p in cm^3) used to make a toy | Number of toys made |
|---|---------------------|
| $0 < p \leq 30$ | 26 000 |
| $30 < p \leq 60$ | 42 000 |
| $60 < p \leq 90$ | 17 000 |
| $90 < p \leq 120$ | 9000 |
| $120 < p \leq 150$ | 6000 |
| Total: | 100 000 |

She works out an estimate of the mean volume of plastic used for each toy.

She wants to reduce this mean by 8%

If she is successful, what will the new mean be?

Give your answer correct to 1 decimal place.

[4 marks]

PAST PAPER

Your answer:

[Total marks: 15]

Activity 4: House extension

4 (a) Abdul wants to build an extension to his house.

The coordinate grid below shows the plan of his back garden where the extension will be.

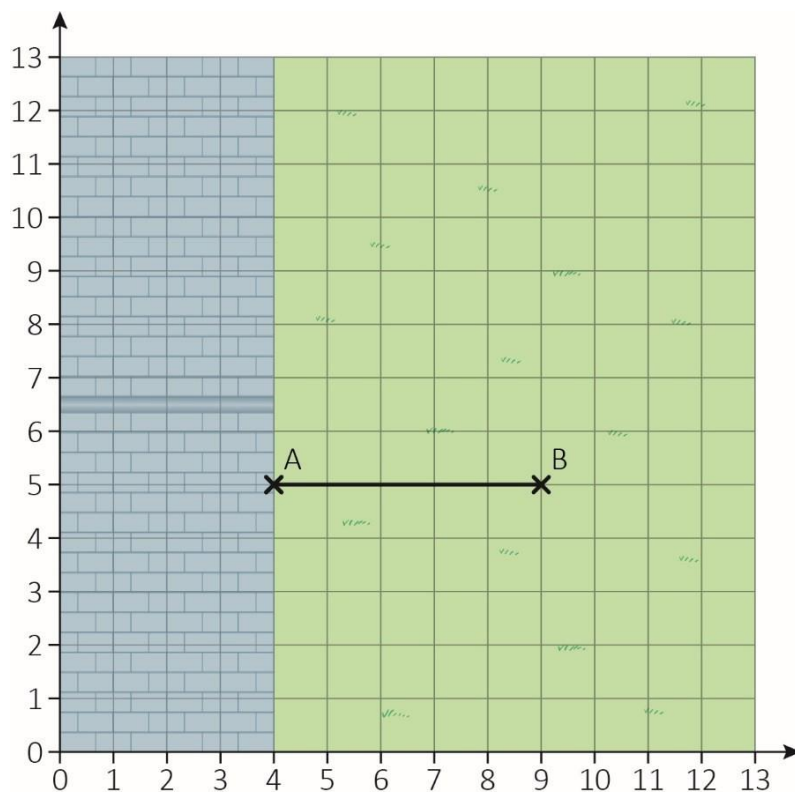

Points A and B are two corners of the extension.
The line AB shows one wall of the extension.

The floor of the extension will be a square.

Write down a set of possible coordinates for the other two corners of the extension.

[2 marks]

Your answer:

Please turn over

4 (b) The diagram shows the shape of the extension.

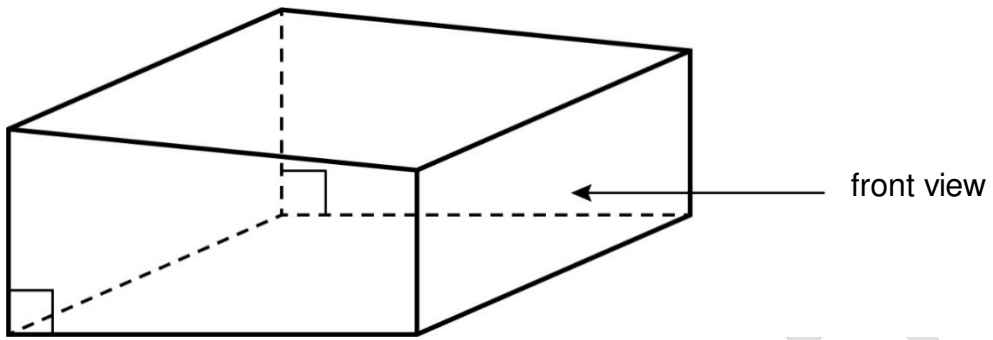

Draw the side view **and** the front view of the extension.

[2 marks]

| |
|------------|
| Side view |
| Front view |

This page has been left intentionally blank.

Please turn over for the next question.

PAST PAPER

- 4 (c) The diagram below shows the dimensions of the extension.

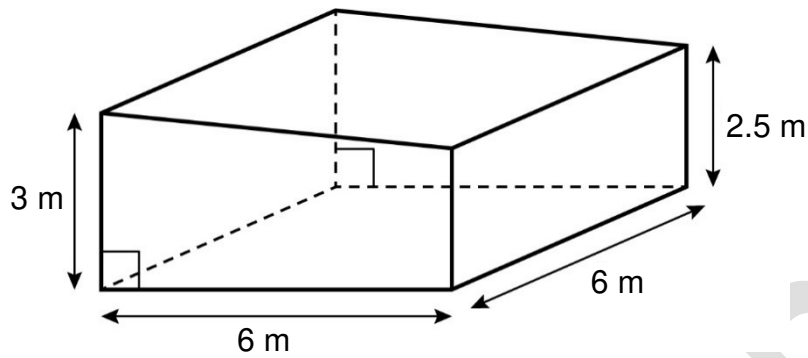

Not drawn
accurately

Abdul wants to work out the power of the heater needed for the extension.

First, he needs to find the volume (V) of air inside the empty extension by using this formula:

$$V = 0.5 \times w \times l \times (a + b)$$

where a = greatest height (m)
 b = smallest height (m)
 w = width (m)
 l = length (m)

Abdul then uses this formula to work out the power of the heater needed for the extension.

$$P = 40V + 100n$$

where P = power of the heater (watts)

V = volume of air inside the empty extension (m^3)

n = the number of windows

There will be 2 windows.

Work out the power of the heater needed for Abdul's extension.

[4 marks]

PAST PAPER

Your answer:

watts

Please turn over

- 4 (d)** Abdul needs to make a planning application.
He must include a scale drawing of the garden and the extension.

The width of the garden is 11.8 metres.
The drawing will use the scale 1 : 200

Abdul thinks that the width of the garden in the scale drawing is 5.4 cm long.

Is Abdul correct?

Show how you decide.

[2 marks]

| | |
|--------------|--|
| | |
| Your answer: | |

4 (e) Abdul finds this information about planning applications to his local council in 2020

| Type of planning application | Received | Granted | Declined |
|------------------------------|----------|---------|----------|
| Major | 270 | 195 | 75 |
| Residential | 306 | 267 | 39 |
| Commercial | 124 | 94 | 30 |

Abdul thinks that, overall, residential applications are more likely to be granted than commercial applications.

Is he correct?

Show how you decide.

[2 marks]

Your answer:

Please turn over

- 4 (f)** Abdul finds this information about planning applications to his local council in 2020

| Type of planning application | Received | Granted | Declined |
|------------------------------|----------|---------|----------|
| Major | 270 | 195 | 75 |
| Residential | 306 | 267 | 39 |
| Commercial | 124 | 94 | 30 |

What is the probability that one of these applications chosen at random is a declined commercial application?

[1 mark]

Your answer:

- 4 (g)** Abdul is granted planning permission.

He does this calculation to work out how much concrete to buy:

$$\frac{(0.2 + 0.05) \times 6^2}{0.9}$$

What answer should Abdul get?

[2 marks]

Your answer:

[Total marks: 15]

This is the end of the assessment.

This page is intentionally left blank.

PAST PAPER

This page is intentionally left blank.

PAST PAPER



Book Your Functional Skills Exam Now!

Intech Centre is a leading training, careers and examination centre based in Islington, London, delivering Functional Skills Maths and English courses and exams for over 26 years.



Book Now!



Book Your Exams & Courses

| Qualification | Private Course | Online Exam | Exam in London |
|---------------------------------------|---------------------------------|----------------------------------|----------------------------------|
| Functional Skills Maths Level 1 & 2 | Enrol on Course | Book Online Exam | Book London Exam |
| Functional Skills English Level 1 & 2 | Enrol on Course | Book Online Exam | Book London Exam |

Why Intech Centre?

- Over **26 years' experience** as a UK training and exam centre in London.
- **City & Guilds Functional Skills Maths and English exams**, Ofqual regulated and nationally recognised.
- Flexible **online learning** with 24/7 access plus online or centre-based exam options.
- Ideal if you still need GCSE Maths or English equivalent for university entry, teacher training, apprenticeships or employment.

CALL US FOR MORE INFORMATION:



020 7354 5655



www.intechcentre.com



info@intechcentre.com